

# APPENDIX D: TYPICAL HIGHWAY CROSS SECTIONS

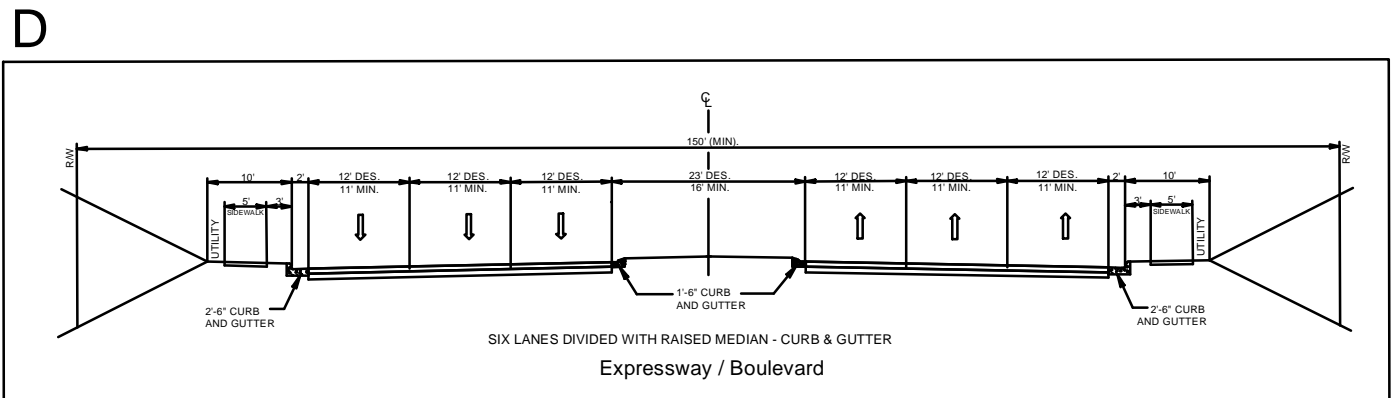

# APPENDIX D: TYPICAL HIGHWAY CROSS SECTIONS

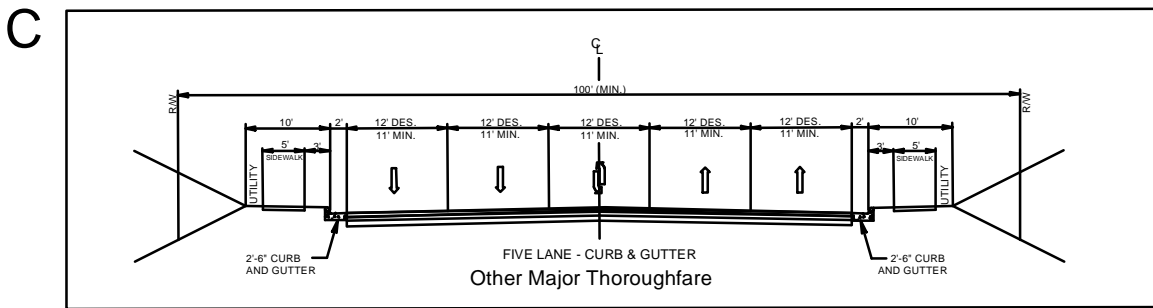
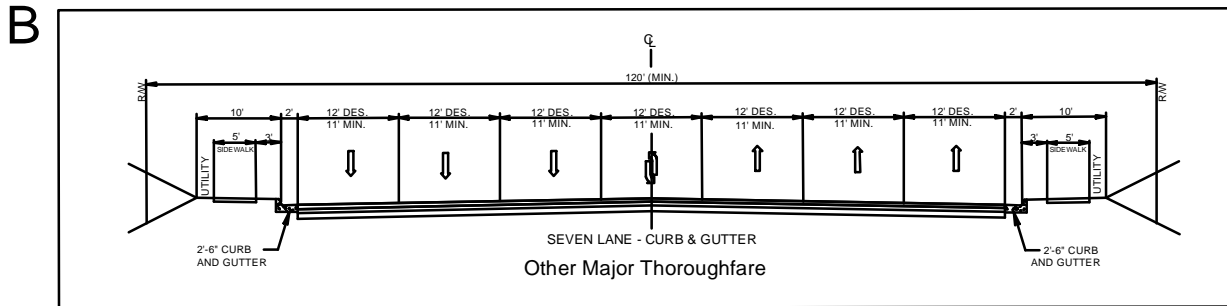
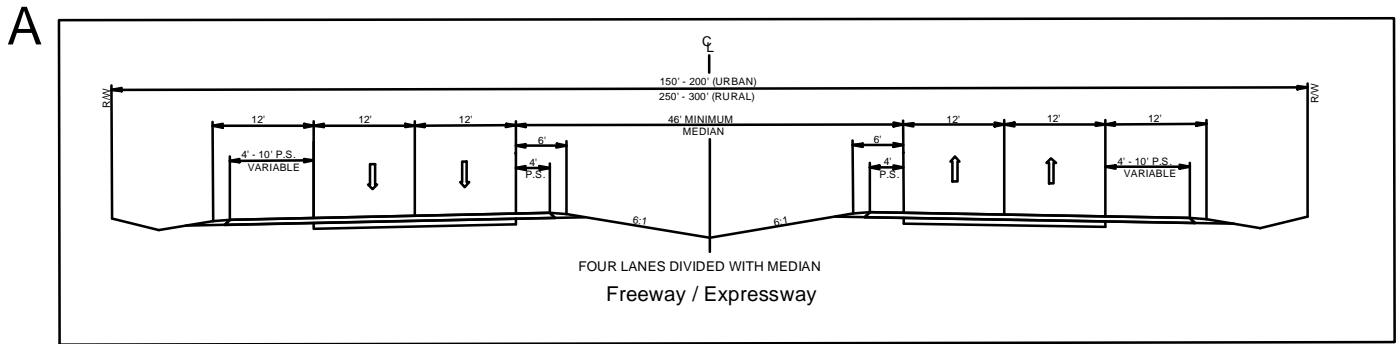
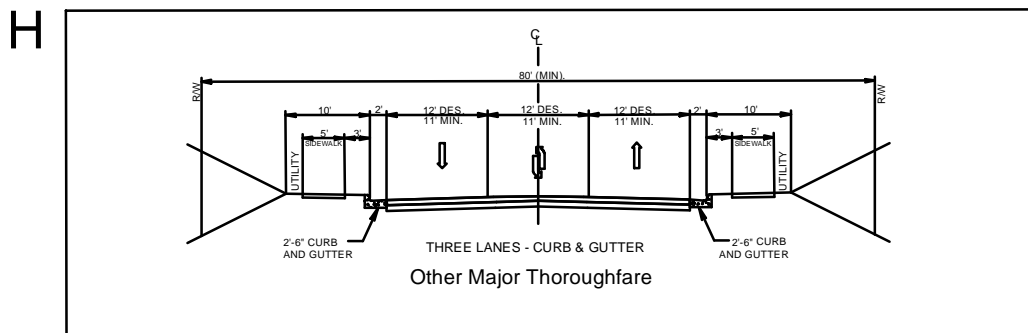
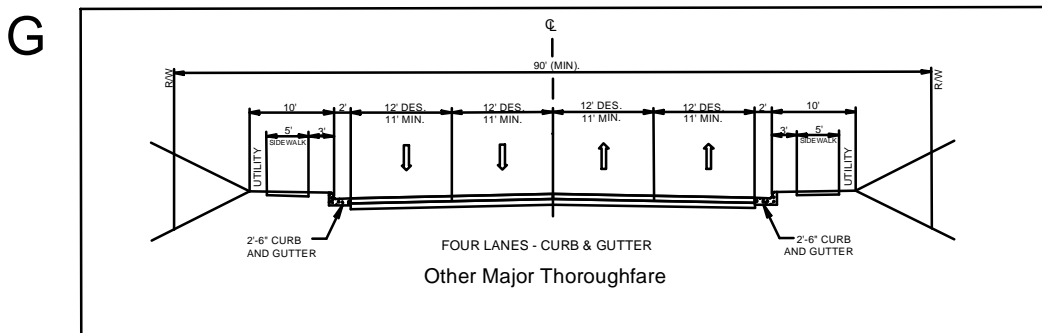
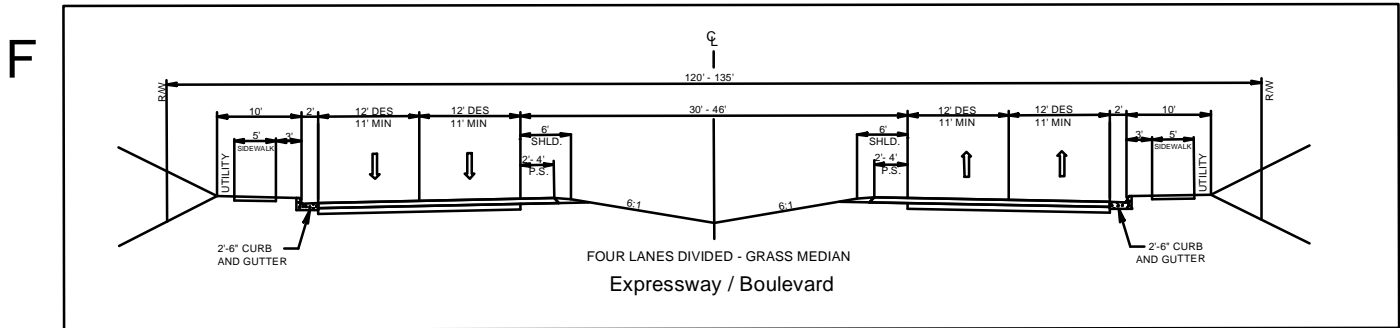
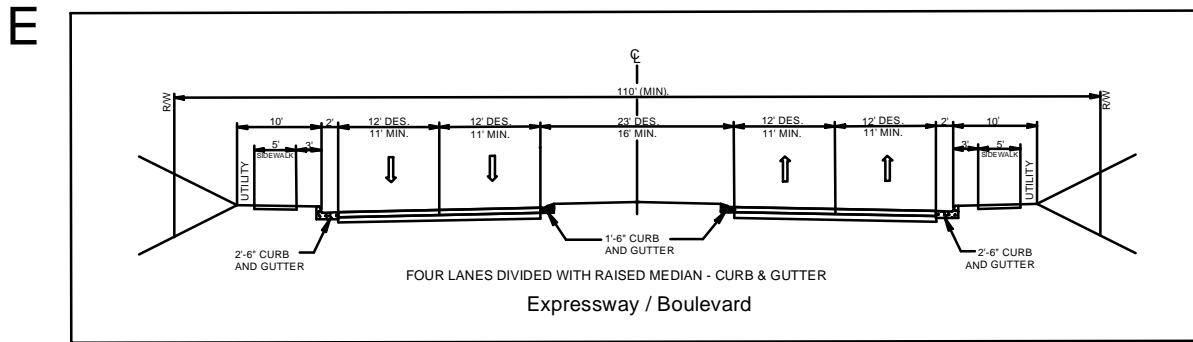

# APPENDIX D: TYPICAL HIGHWAY CROSS SECTIONS

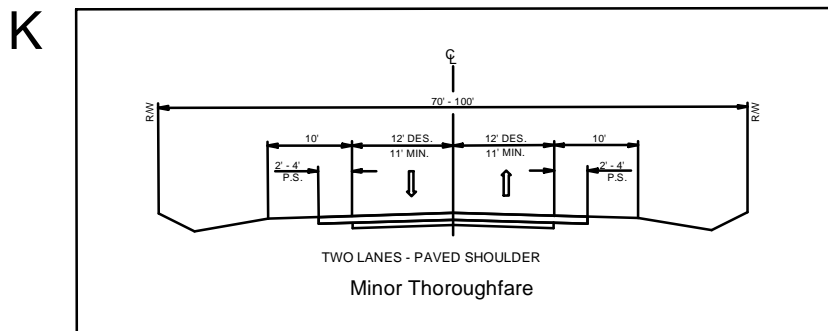
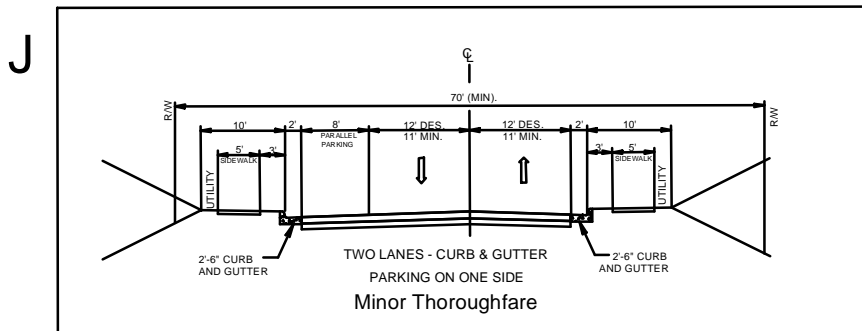
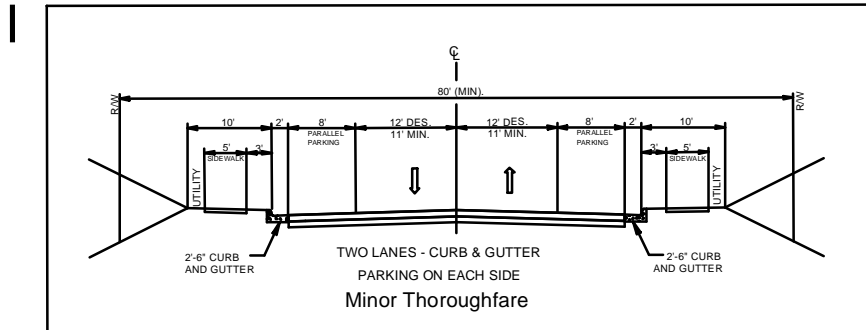

# APPENDIX D:

## TYPICAL HIGHWAY CROSS SECTIONS

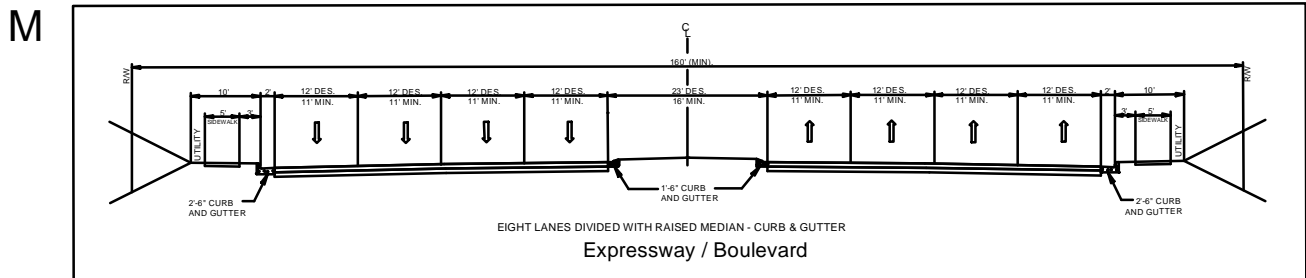
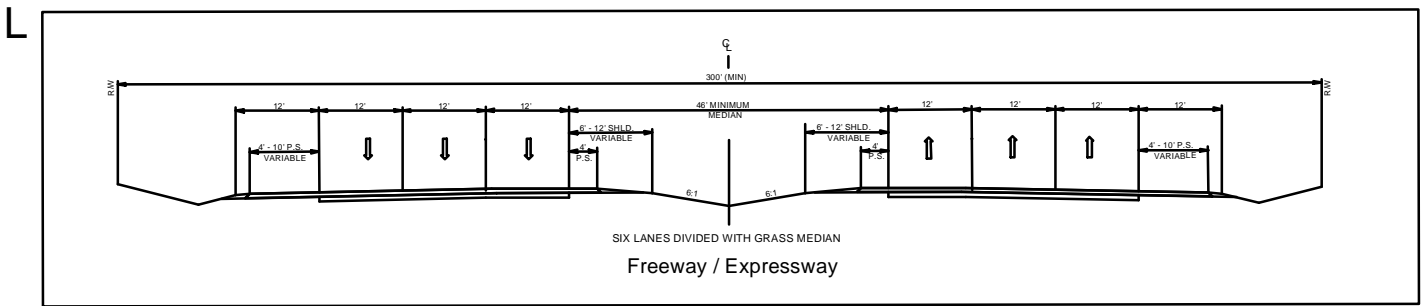

# Typical Bicycle Cross Sections

## WIDE CURB LANES

### B-1 4-LANE MEDIAN DIVIDED TYPICAL SECTION

With Wide Outside Lanes

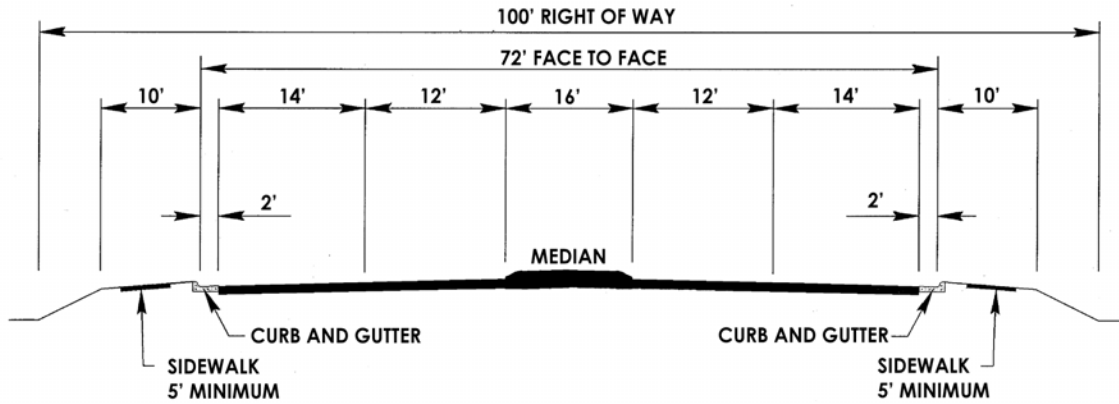

### B-2 5-LANE TYPICAL SECTION

With Wide Outside Lanes

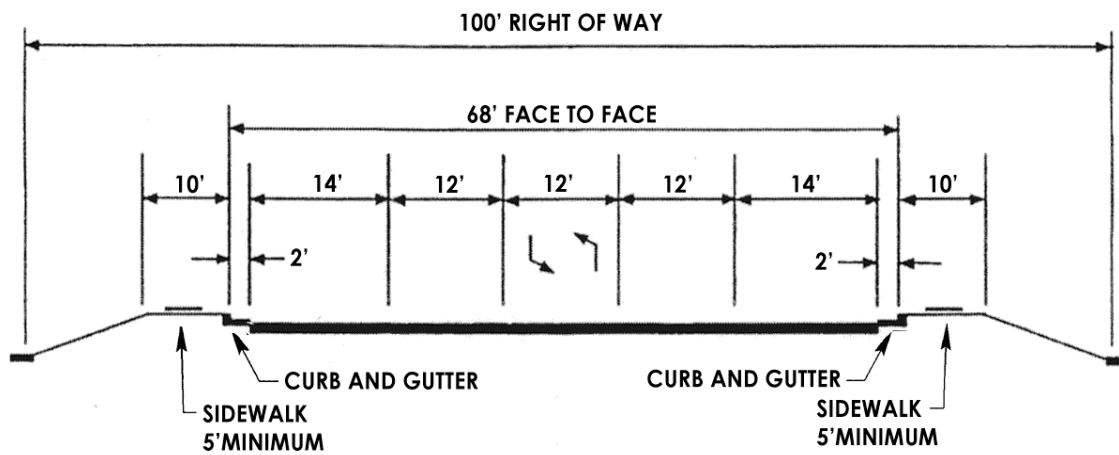

# Typical Bicycle Cross Sections

## **B-3 BICYCLE LANES ON COLLECTOR STREETS**

**Existing Roadway**

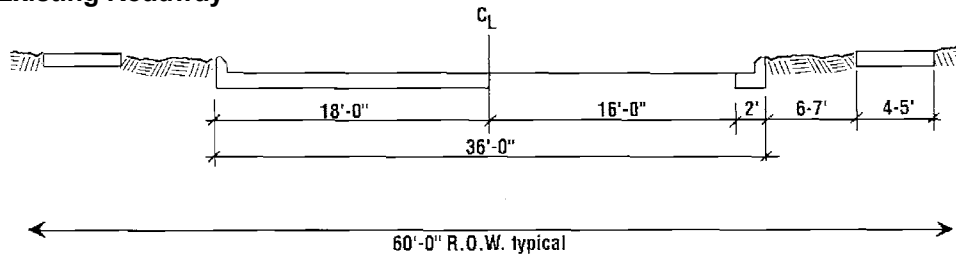

**Restriping to Accommodate  
Bicycle Lanes (Does Not Allow  
On-Street Parking)**

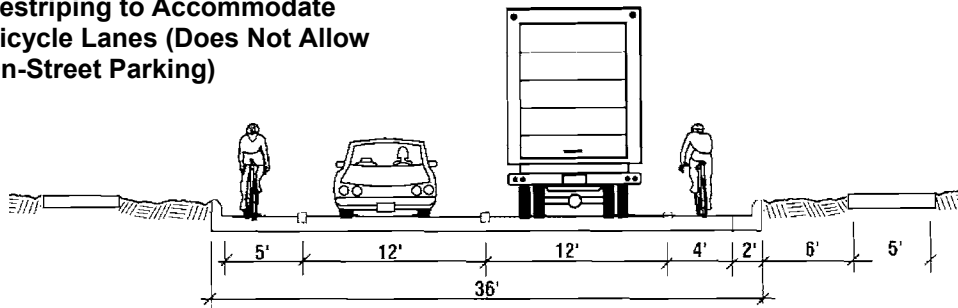

# Typical Bicycle Cross Sections

## **B-4 WIDE PAVED SHOULDERS**

Existing Roadway

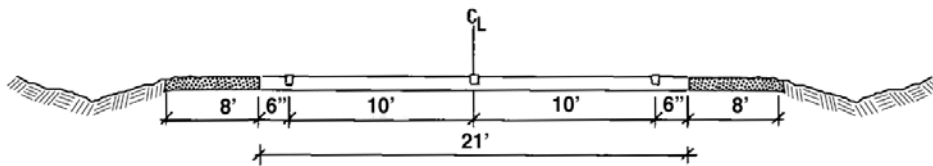

Roadway Retrofitted with  
4-Ft Paved Shoulders

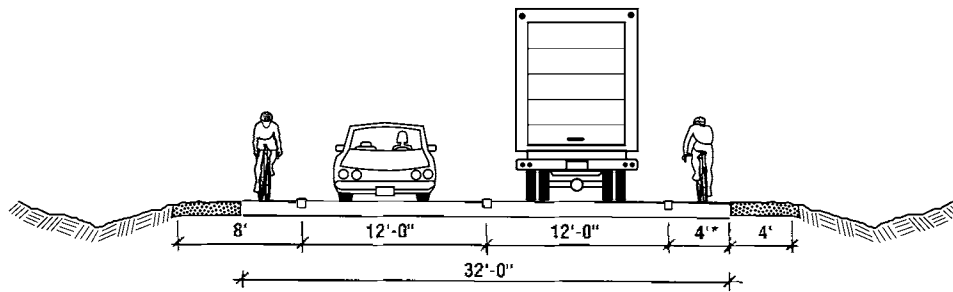

\* If speeds are higher than 40 mph,  
shoulder widths greater than 4' are  
recommended.

## Typical Bicycle Cross Sections

### **B-5 RECOMMENDED TYPICAL SECTION OF 10-FT ASPHALT PATHWAY With 2-Ft Select Material Shoulder**

